



**210 E. Locust, St
Stanfield, OR 97875**

Toll Free: 1-866-499-2199

Business: 1-541-499-2199

Fax: 1-541-499-2182

22525 I-40

Knoxville, AR. 72830

Toll Free: 1-866-267-3790

Business: 1-479-885-1258

Fax: 1-479-885-6021

**340 Centennial Dr.
Heyburn, ID. 83336**

Toll Free: 1-866-597-5758

Business: 1-208-436-3157

Fax: 1-208-436-3581

**12721 I-27
Amarillo, TX. 79118
Toll Free: 1-866-882-0597
Business: 1-806-622-0073
Fax: 1-806-622-1984**

**3702 Industry Dr.
Gallup, NM. 87305
Toll Free: 1-866-789-9064
Business: 1-505-722-5691
Fax: 1-505-722-5834**



**©Copyright 2007 by Coast to Coast Carports, Inc.
All Rights Reserved.**

Coast to Coast Carports, Inc.



INSTALLATION MANUAL

(12' to 30' Wide Models)

STEP BY STEP GUIDE TO INSTALLATING COAST TO COAST CARPORTS

www.coast-to-coastcarports.com

CONTENTS

THANK YOU!

All of us at Coast To Coast Carports Inc., sincerely thank you for choosing us as your carport supplier. These easy to use assembly instructions will make building your new carport quick and simple. Please read them thoroughly before assembly so that you can get familiar with the parts and tools that you will need. It is your responsibility to comply with all building codes and obtain the proper permits when necessary.

If you are missing a part or you have a question concerning assembly, we are only a phone call away. We will quickly ship any part that is missing or damaged, and we will answer any question in a timely manner. We are in the communications business, and we want you to be 100% satisfied.

Good luck, and thank you again for choosing us as your carport company.

Coast to Coast Carports, Inc.

1.	SAFETY INFORMATION	2
2.	GENERAL DESCRIPTION	3
3.	PARTS LIST	4
4.	PARTS DESCRIPTION AND QUANTITY.....	5
5.	TOOLS LIST.....	6
6.	BASE INSTALLATION	7
7.	FRAME ASSEMBLY	7
8.	FRAMES TO BASE ASSEMBLY	9
9.	ANCHORING	10
10.	MEASUREMENT VERIFICATION	11
11.	ROOF PANEL ASSEMBLY	12
12.	TRIM ATTACHMENT.....	16
13.	SECURING STRUCTURE	17

1. SAFETY INFORMATION

For your safety and for proper installation, please read the following instructions carefully, in case you have further questions or are missing parts, please contact our company before starting the installation process.

WARNINGS:

1. INSTALLATION IS NOT RECOMMENDED ON WINDY DAYS AS COMPONENTS WILL BE DIFFICULT TO HANDLE.
2. ALWAYS WEAR SAFETY GLASSES AND GLOVES DURING THE INSTALLATION.
3. AVOID CONTACT WITH SKIN AS METAL PIECES TEND TO GET HOT WHEN EXPOSED TO DIRECT SUNLIGHT.
4. KEEP THE COMPONENTS AWAY FROM ALL ELECTRICAL SOURCES DURING ALL STAGES OF THE INSTALLATION.
5. THE STRUCTURE CAN ONLY MEET THE SPECIFIED DESIGN LOADS ONCE IT HAS BEEN FULLY INSTALLED. DO NOT LOAD OR STAND/WALK ON THE STRUCTURE WHILE IT IS BEING ASSEMBLED.
6. STEEL ROOF PANELS HAVE SHARP EDGES. HANDLE THE PANELS CAREFULLY AND AVOID TOUCHING THE EXPOSED EDGES. ALWAYS USE STRONG PROTECTIVE GLOVES.
7. UNTIL THE STRUCTURE IS FULLY ANCHORED INTO THE GROUND, THE COMPONENTS MIGHT TEND TO MOVE AND CHANGE ORIENTATION. IF THE STRUCTURE IS BEING MOVED AFTER ASSEMBLY, ENSURE THAT THE DIMENSIONS AND ALIGNMENTS ARE CORRECT.

2. GENERAL DESCRIPTION

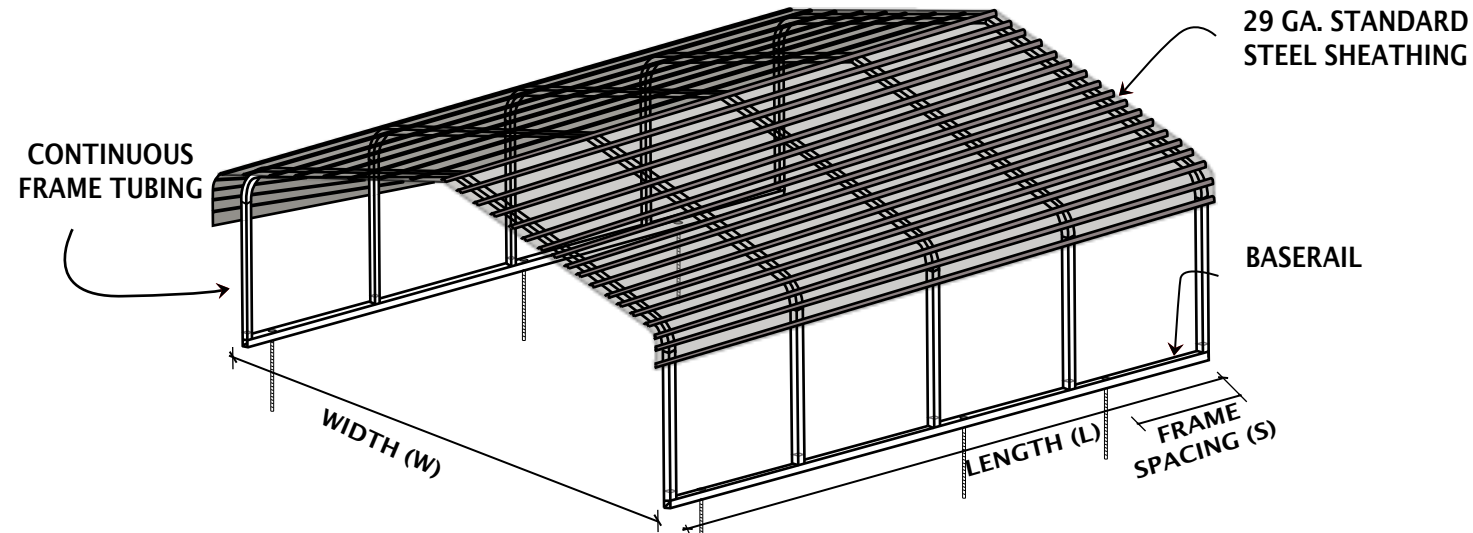

Our carports are designed to ensure quick assembly as well as to provide an aesthetic finish. Follow this step by step guide to complete the simple set-up procedure. In case any parts are missing or arrive damaged, please contact our office.

NOTES:

- 2.1 These instructions are general in nature and apply to carports of sizes 12' to 30' wide. Some details shown here may vary from your individual carport. Please view the engineering plans for details for your carport.
- 2.2 The carport is designed to meet the local code requirements for dead and live loads. The design criteria can be found on the accompanying plans.
- 2.3 The anchoring options provided are designed to support the structures against expected wind uplifts as required by the local building code.
- 2.4 Tube sizes, gauges as well as frame layout and spacing vary depending on carport width, enclosed sides, as well as load requirements. Please refer to the engineering plans for correct specifications.
- 2.5 The steel rib sheathing has to be a minimum of 29 GA. thickness

OPTIONS:

- 2.6 Building width (W), length (L) and height (H) will be as ordered
- 2.7 Frame spacing (S) as well as tube sizes for the arch and column members vary. Please refer to the engineering plans for details.
- 2.8 For other anchor options, anchor sizes and layout, please refer to the engineering plans.
- 2.9 Arch may be provided as either unbraced, single-braced or double-braced as needed. Please refer to the engineering plans for verification.
- 2.10 For some cases, columns may need to be doubled by either inserting or attaching adjacently. Again, refer to the engineering plans for correct specifications

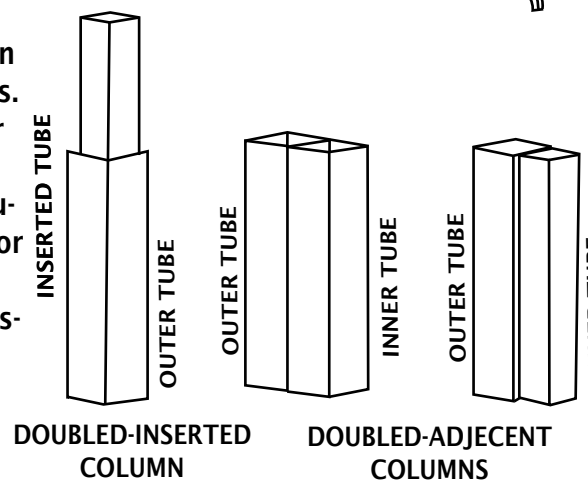
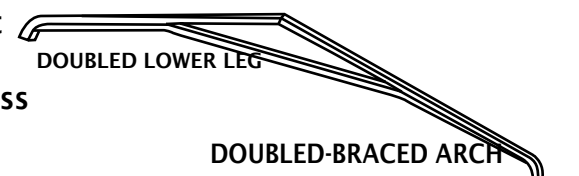
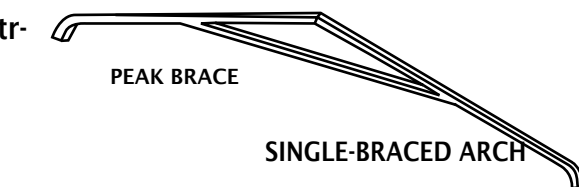
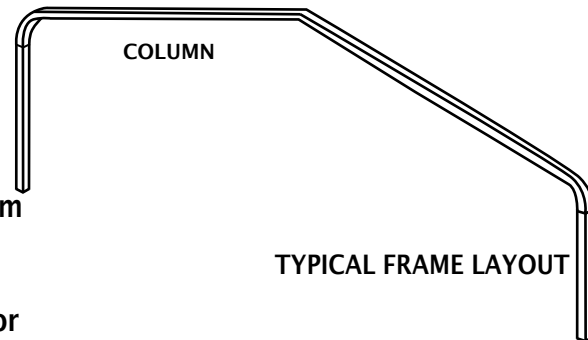

3. PARTS - LIST

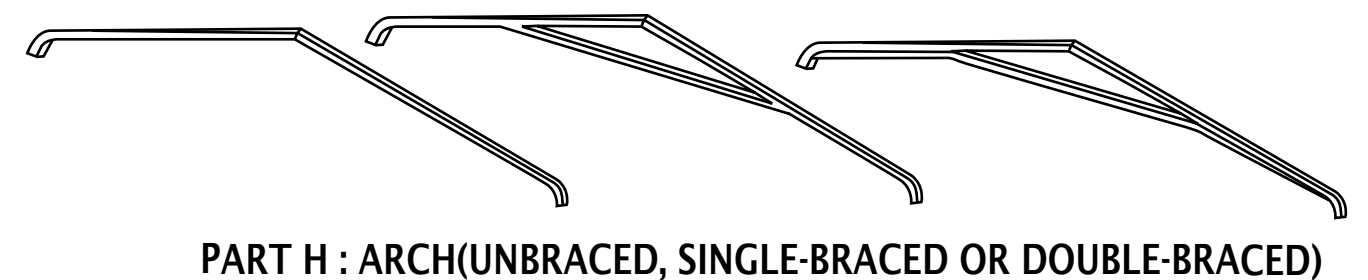
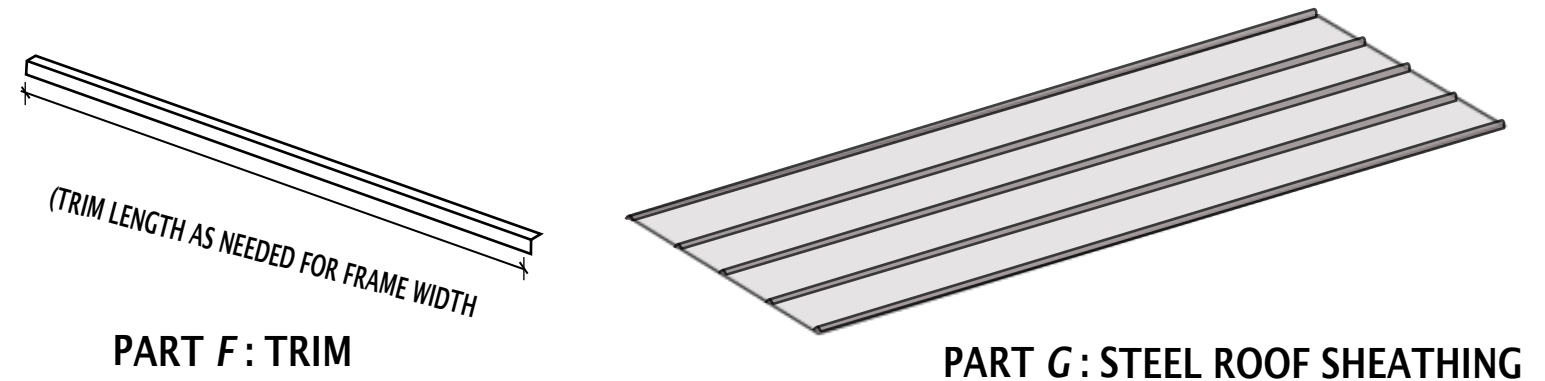
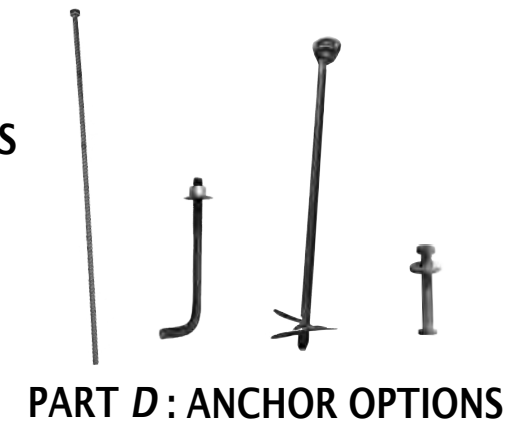
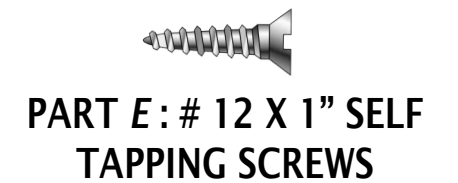
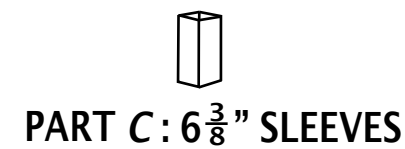
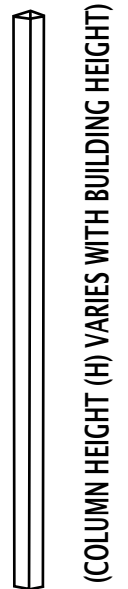
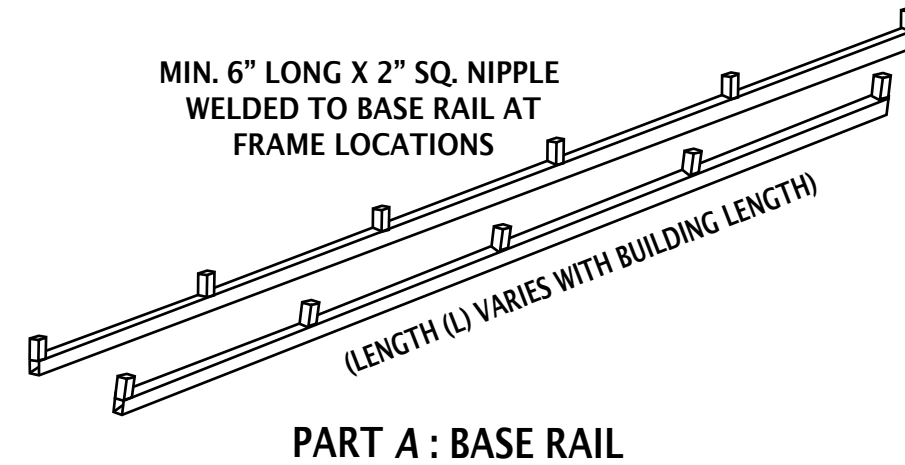

4. PARTS- DESCRIPTION AND QUANTITY

PART	DESCRIPTION	LENGTH	QUANTITY
A	BASE RAIL - 12 GA. & 14 GA. STRUCTURAL STEEL TUBE SEE ENGINEERING PLANS FOR TUBE SIZES	AS NEEDED FOR BUILDING LENGTH	2 RUNS - EACH RUN MIGHT BE MADE UP OF MORE THAN ONE PIECE
B	COLUMNS - STRUCTURAL STEEL TUBE. SEE ENGINEERING PLANS FOR STEEL GAUGE AND TUBE SIZES.	MATCHES EVE HEIGHT OF BUILDING	2 PER FRAME*
C	SLEEVES - STRUCTURAL TUBE STEEL SLEEVES FOR CONNECTING ARCH MEMBERS TO COLUMNS	6 ³ / ₈ "	2 PER FRAME*
D	ANCHOR OPTIONS - SEE ENGINEERING PLANS FOR AVAILABLE ANCHOR OPTIONS	VARIES - SEE PLANS	AS SPECIFIED IN ENGINEERING PLANS
E	SCREWS - # 12 SELF DRILLING / SELF-TAPPING SCREWS	1"	MIN. 1 BAG
F	TRIM - LIGHT GAUGE STEEL TRIM	AS NEEDED TO COVER EDGES OF SHEATHING	
G	SHEATHING - MIN 29 GA. CORRUGATED STEEL ROOF PANELS 36" WIDE	AS NEEDED FOR BUILDING LENGTH	AS NEEDED FOR COVERED AREA. PLEASE SEE PAGE 9 OF THIS GUIDE
H	ARCHES - STRUCTURAL STEEL TUBE ARCHES. DESIGN VARIES, PLEASE SEE ENGINEERING PLANS	WIDTH AS SPECIFIED SEE ENGINEERING PLANS	1 PER FRAME*

* PLEASE SEE ENGINEERING PLANS FOR FRAME SPACING AND NUMBER OF FRAMES

5. TOOLS REQUIRED



STEP LADDER - (2)



ELECTRIC OR BATTERY POWERED SCREW GUN - (1)



TAPE MEASURE - (1)



SAFETY GLASSES - (2 PAIRS)



WORK GLOVES - (2 PAIRS)



BUBBLE LEVEL - (1)



TIN SNIPS - (1 PAIR)



SLEDGE HAMMER - (1)

6. BASE INSTALLATION

- 6.1 Place base rail (A) on a level surface. Preferably, assemble the carport at the location where it is to be installed.
- 6.2 Align the base rails (A) parallel to each other at "W" distance apart. Using the tape measure, ensure both ends to the rails (A) are equidistant at "W" from each other. Check the engineering plans for the exact dimensions for your carport.
- 6.3 Measure the distance to diagonally opposite corners of the structure. These should be equal to each other and should follow the Pythagorean theorem (square of cross distance should be equal to squares on the length and width). Please see the table provided for different lengths and widths to determine diagonal cross distance length.

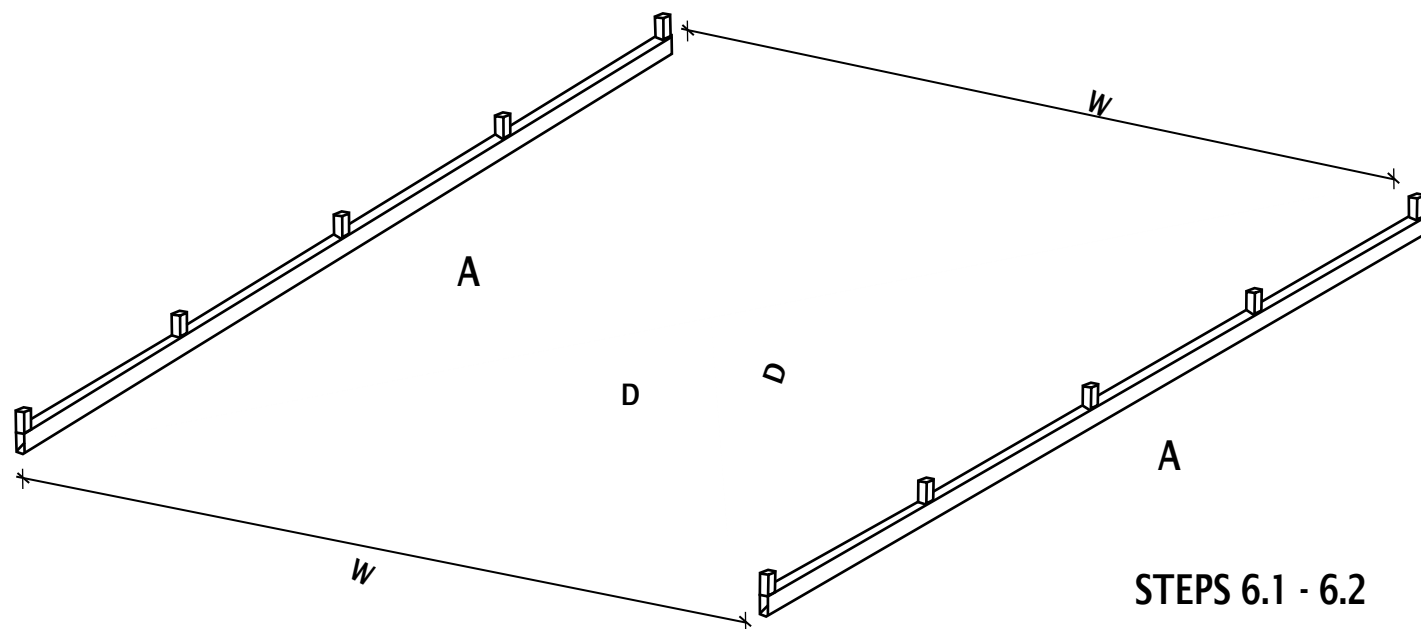

7. FRAME ASSEMBLY

- 7.1 Insert sleeves (C) half way into the columns (B). Secure the sleeves (C) by self tapping screws (E) on two opposite tube faces.

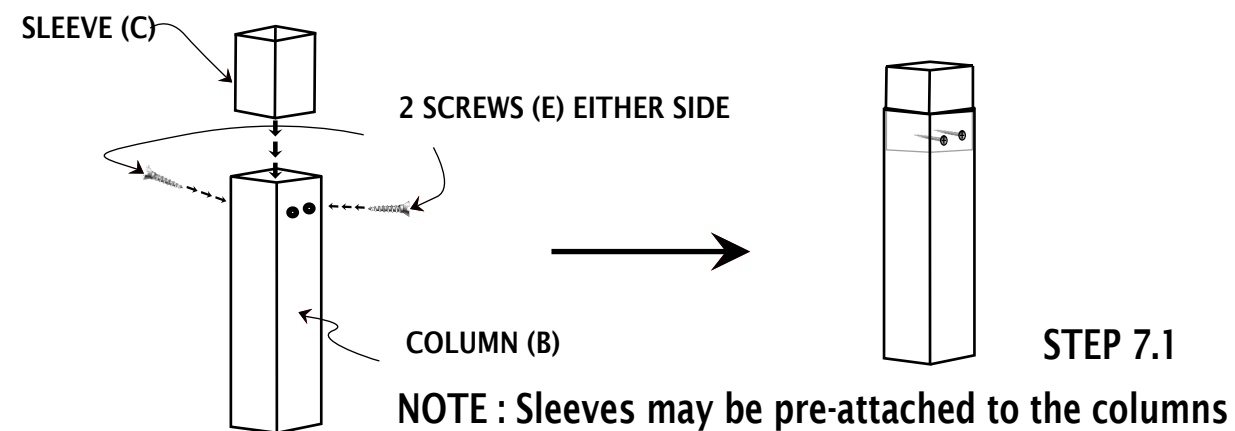

7. FRAME ASSEMBLY

- 7.2 Insert other end of the sleeve (C) to the arch (H). Attach with two screws (E) similar to step 6.1. The screws (E) have to be on the front and back of the arch (H) as shown.

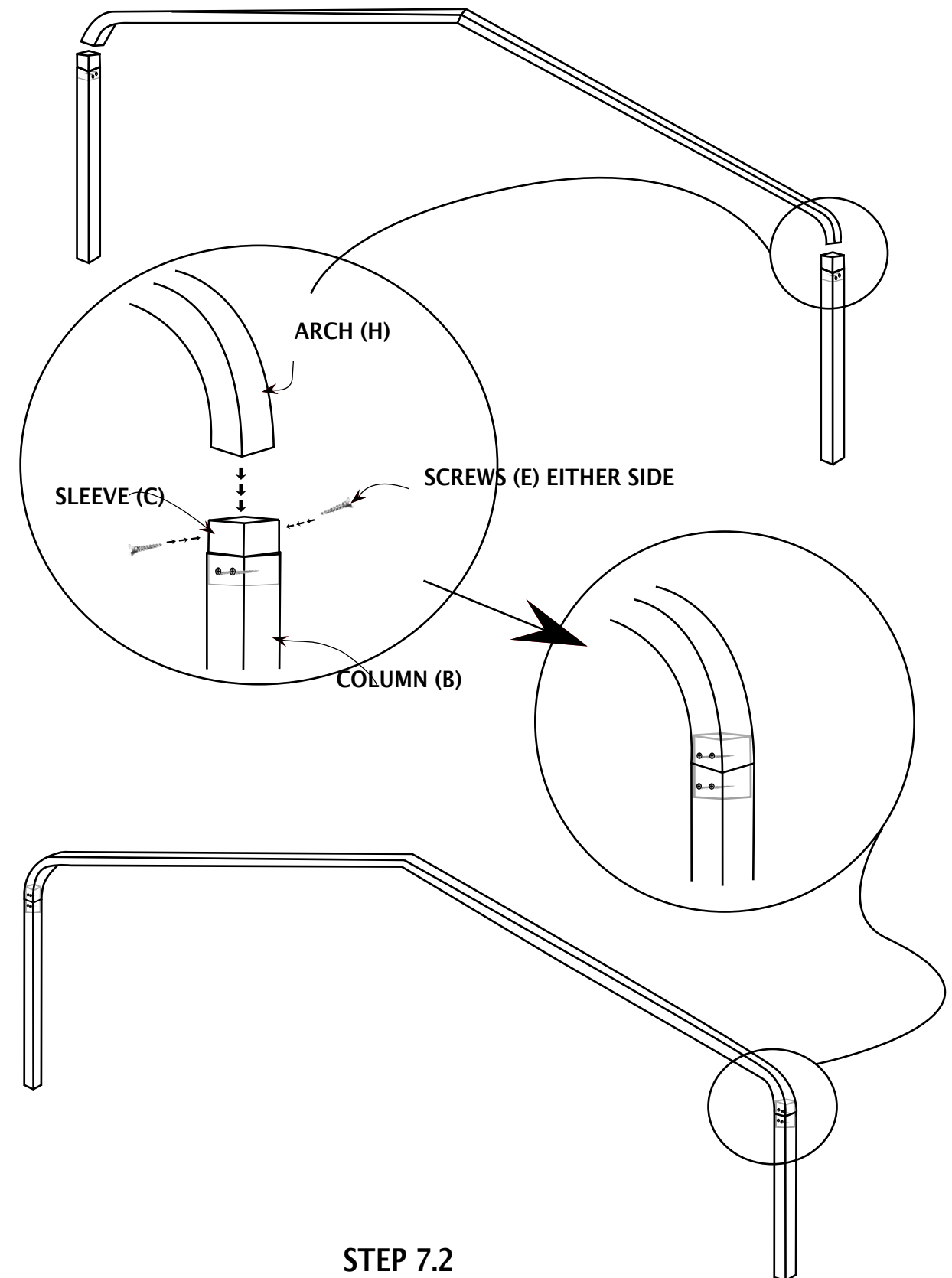

8. FRAME TO BASE ASSEMBLY

8.1 Insert assembled frame over sleeve of base rail (A). Column tubes (B) many need to be hammered out slightly to fit over base rail sleeves. **DO NOT ATTACH THE ASSEMBLED FRAME TO BASE RAILS WITH SCREWS.**

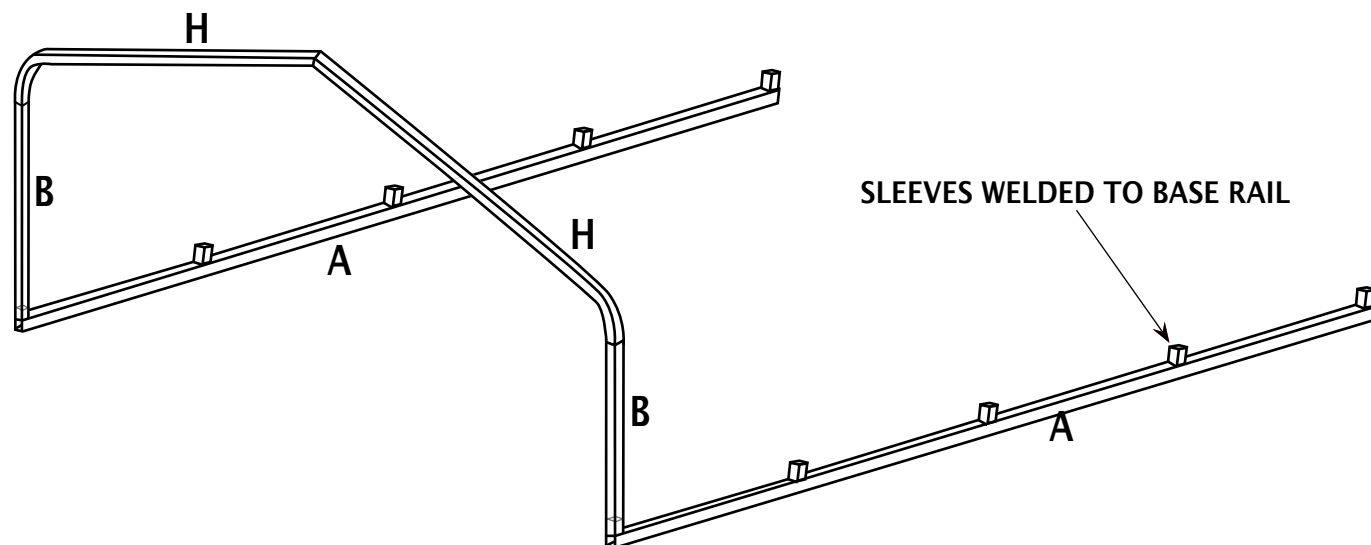

STEP 8.1

8.2 Repeat steps 7 thru 8.1 for all frames. **DO NOT** anchor to ground as yet.

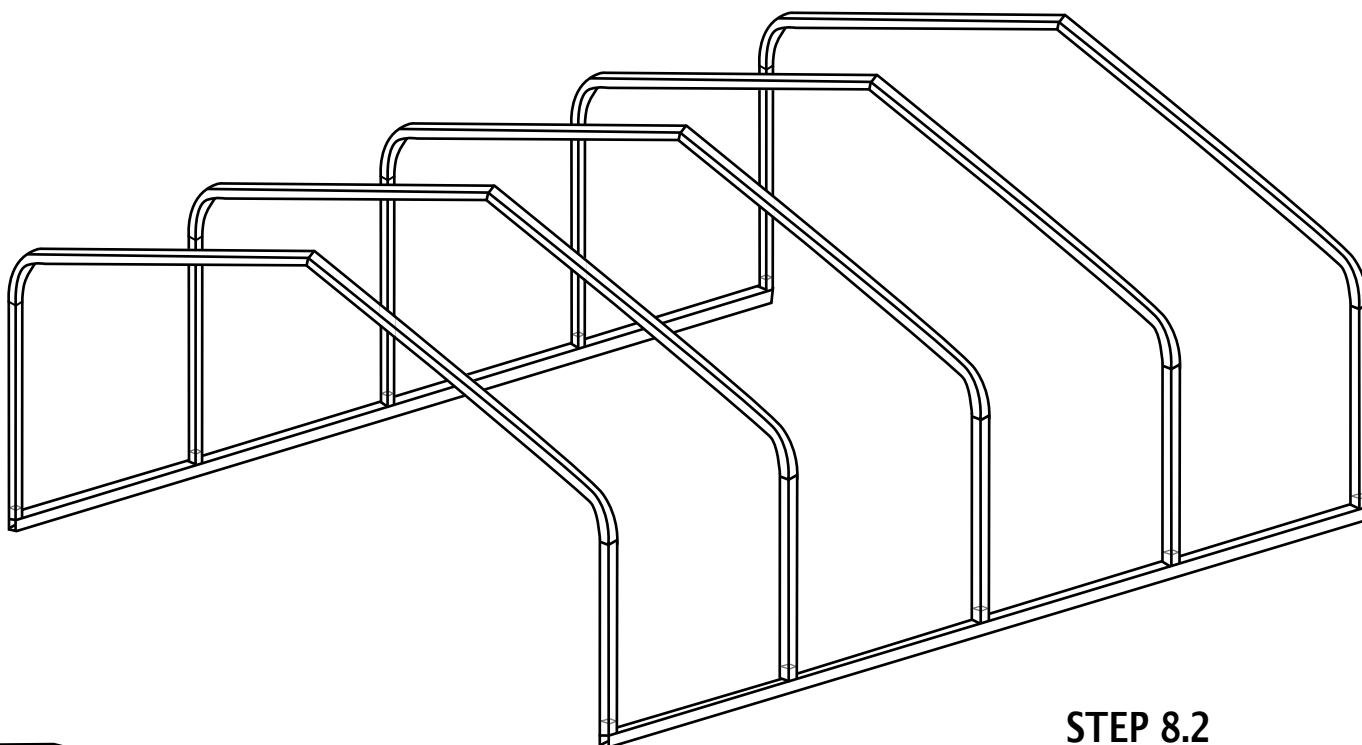

STEP 8.2

9. ANCHORING

9.1 Mark the anchor locations on the base rails (A). If the rails do not have pre-drilled holes for the anchors, drill the holes at the anchor locations. Please see the engineering plans to determine where the anchor locations should be. **AT THIS STAGE, ONLY ONE RAIL SHOULD BE ANCHORED TO THE GROUND.**

9.2 Use one of the following anchor options (a, b., c or d) to anchor one of the base rails into the ground.

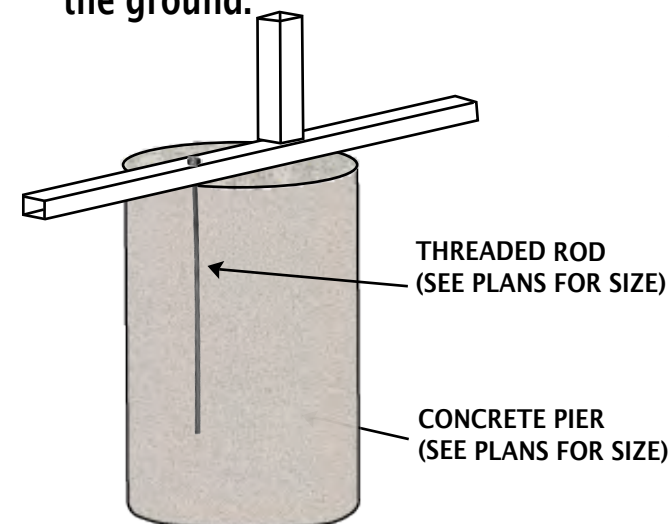

a. Pier Foundation with Threaded Rod:
Align the anchor holes on the base rails with the pier locations. Insert the threaded rod through the anchor holes on the base rails. Fill each hole with 3000 psi concrete. Please verify specs with the engineering plans

b. Pier Foundation with J-Bolt:
Align the anchor holes on the base rails with the pier locations. Insert the J-bolt through the anchor holes on the base rails. Fill each hole with 3000 psi concrete. Please verify specs with the engineering plans.

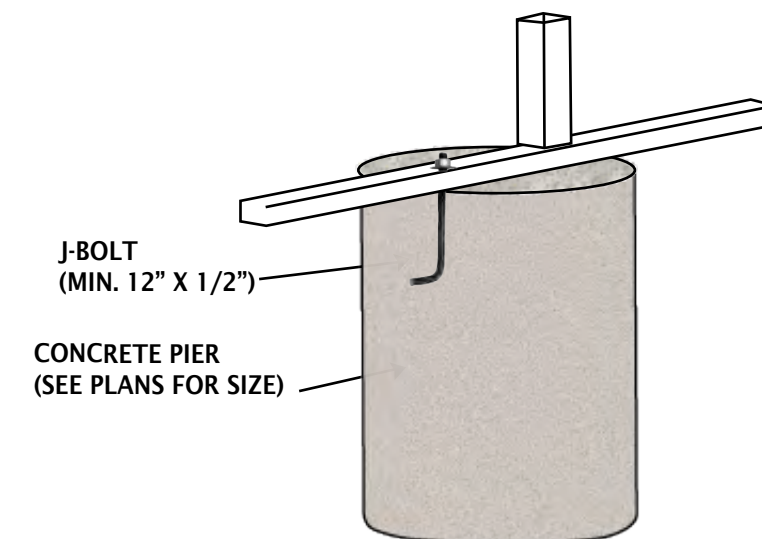

c. Helical Anchor
For anchoring with helical anchors, position the helical anchor locations adjacent to the base rails as shown. The anchors have to be bolted to the base rails through the sides as shown below.

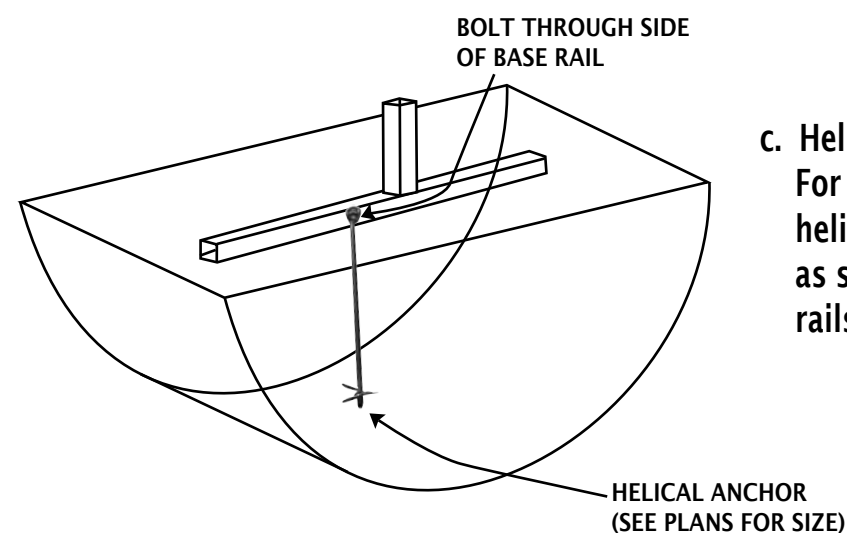

d. Concrete Foundation with Expansion Bolt:
Follow instructions as specified by expansion bolt manufacturer.

10. MEASUREMENT VERIFICATION

For proper installation, it is essential to verify the measurements. Please follow the steps below to ensure the structure has been properly installed.

10.1 Using a bubble level, ensure all columns (B) are vertical.

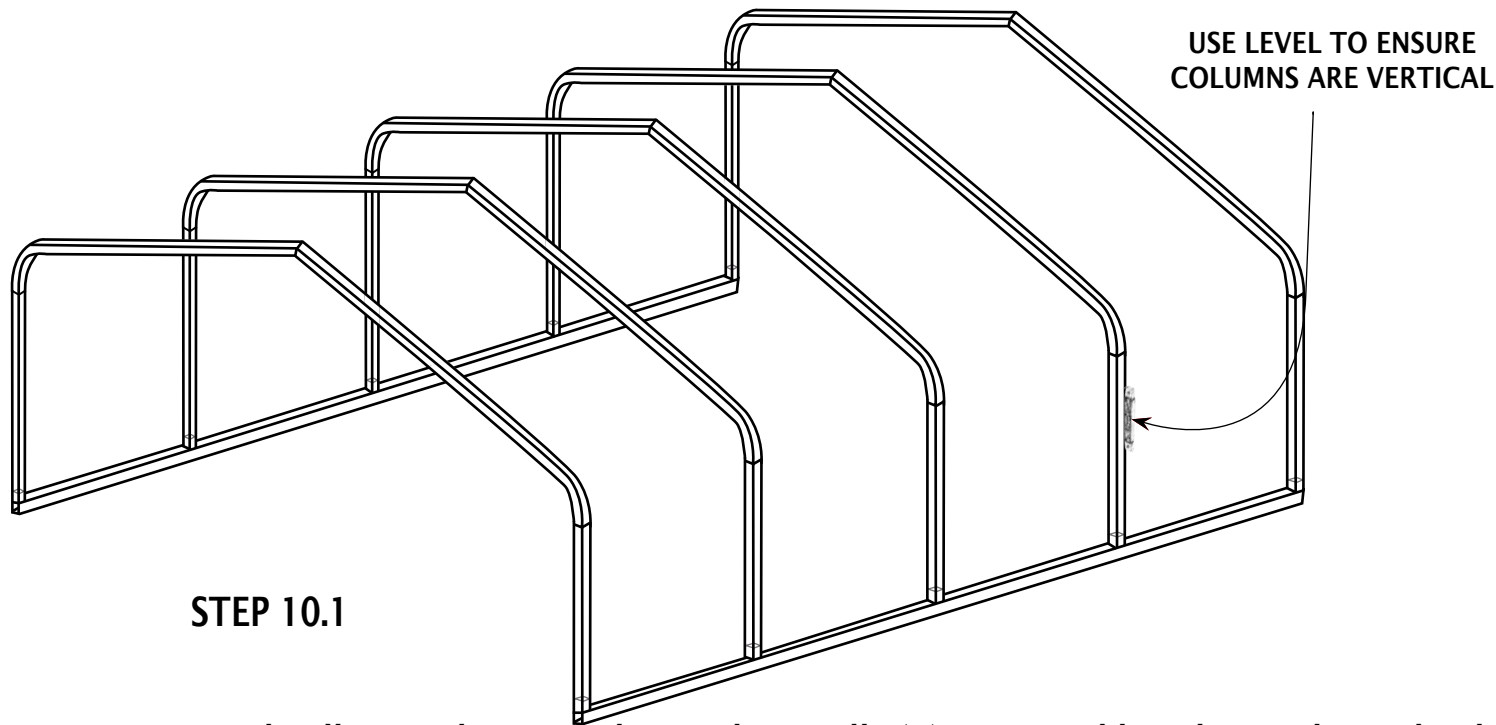

STEP 10.1

10.2 Measure the distance between the two base rails (A) at several locations. These should equal to the carport width 'W'.

NOTICE : Also make sure to *REPEAT* step 6.3 to make sure everything is measured correctly

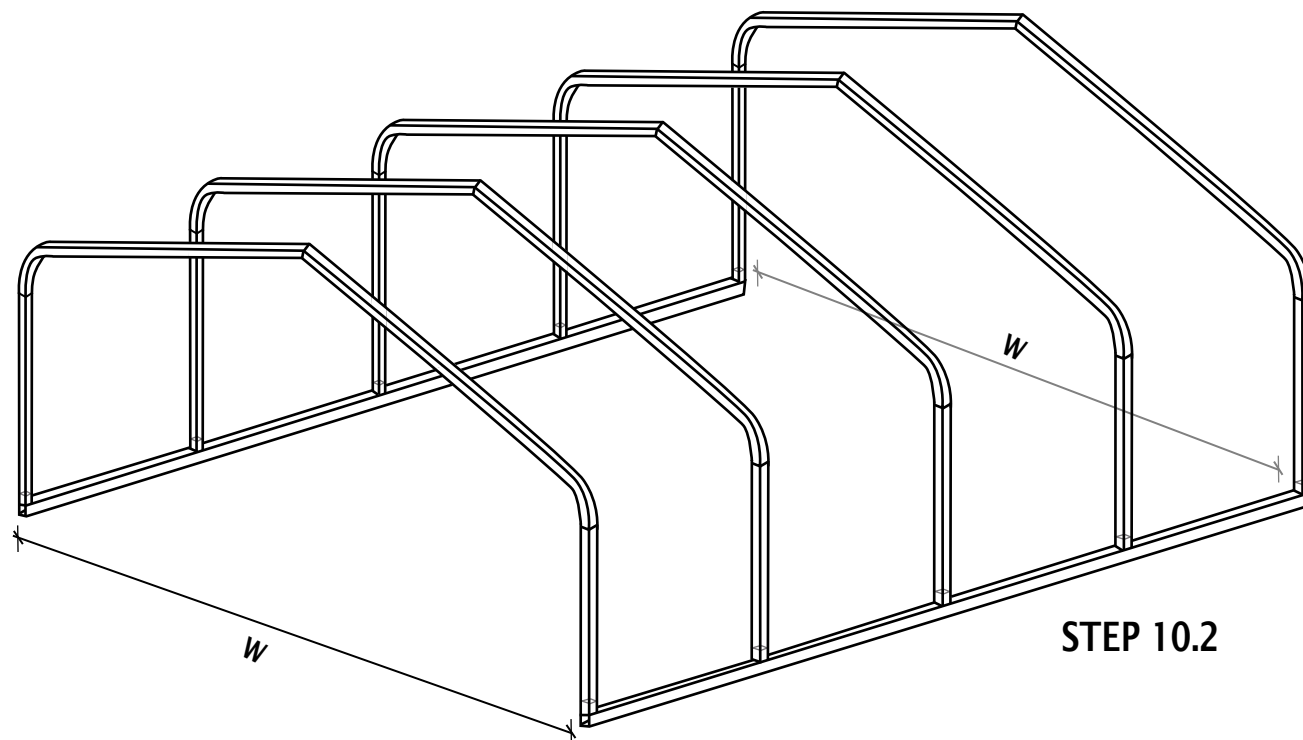

STEP 10.2

11. ROOF PANELS ASSEMBLY

NOTICE : Before starting to install panels make sure to *REPEAT* step 6.3

CAUTION : Steel roof panels may have sharp edges. Wear work gloves and handle with care.

NOTICE: The amount of panels vary according to the width of your carport.

WIDTH	PANELS	WIDTH	PANELS
12	5	24	9
18	7	26	10
20	8	28	10
22	9	30	11

11.1 Mark the first panel (using a pencil) at a distance of 6" from each end on both sides as shown. This will allow for the 6" over hang.

MARK PANEL FOR OVERHANG

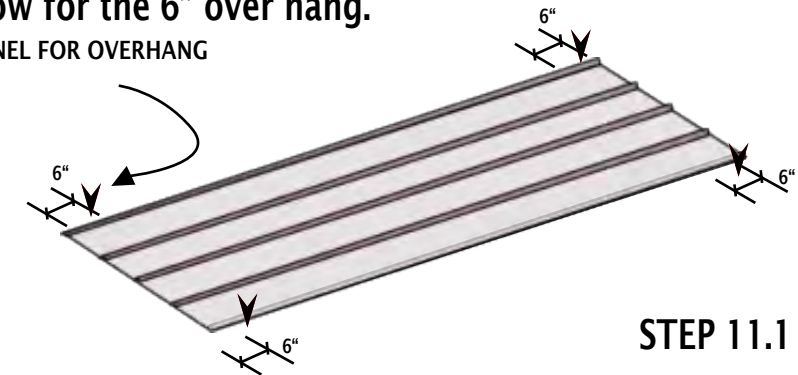

STEP 11.1

11.2 NOTICE : Panel assembly changes according to the width of your carport.

Using two ladders, one at each end, raise the panel to the top of the columns.

NOTICE: For the 12, 18, 22, 24, 26, 28 and 30 wide carports it is necessary to align the center rib of the panel to the center of each arch. (The center of each arch is marked by a pencil mark.) Make sure to align the panel with the first arch according to the 6" mark for the overhang.

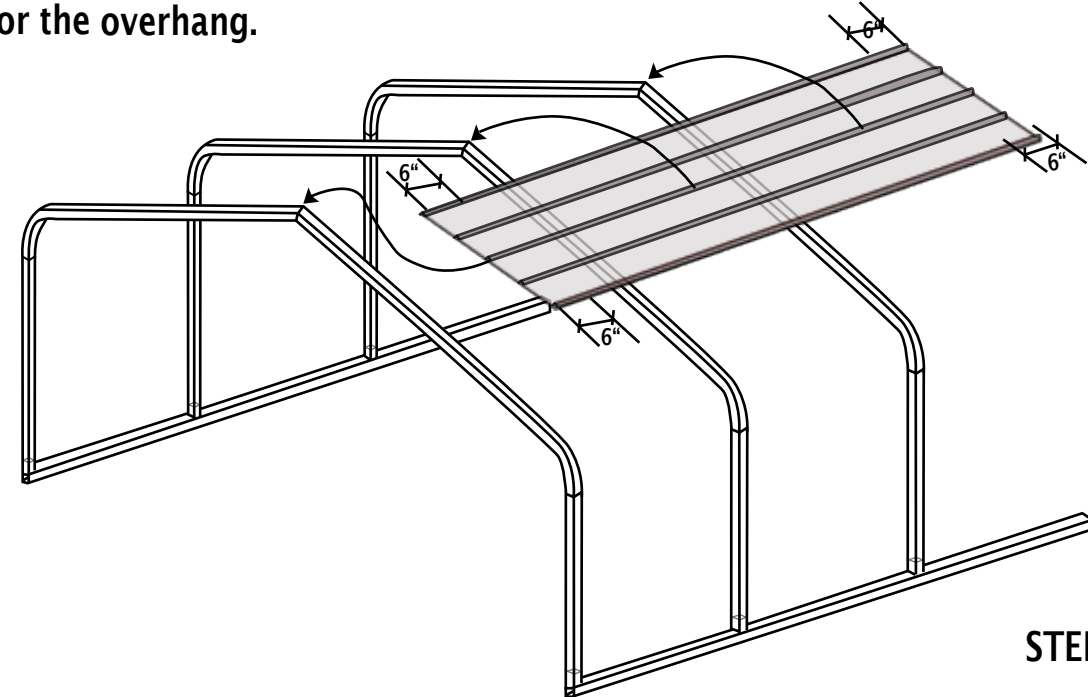

STEP 11.2

11. ROOF PANELS ASSEMBLY

11.3 Properly aligning the first panel is important as it will square up the structure. Secure the panel to the arches using the self tapping screws (E). Place one screw between second, third and fourth major ribs on each arch. At this time do not place the screws between the edge ribs. DO NOT over drive screws. Washers should be snug but not flattened. It is a good idea to pre-drill holes as it will make it easier to attach the panels.

NOTE : If more than one panel is needed to cover the length, add caulking to the top of the lapped panel.

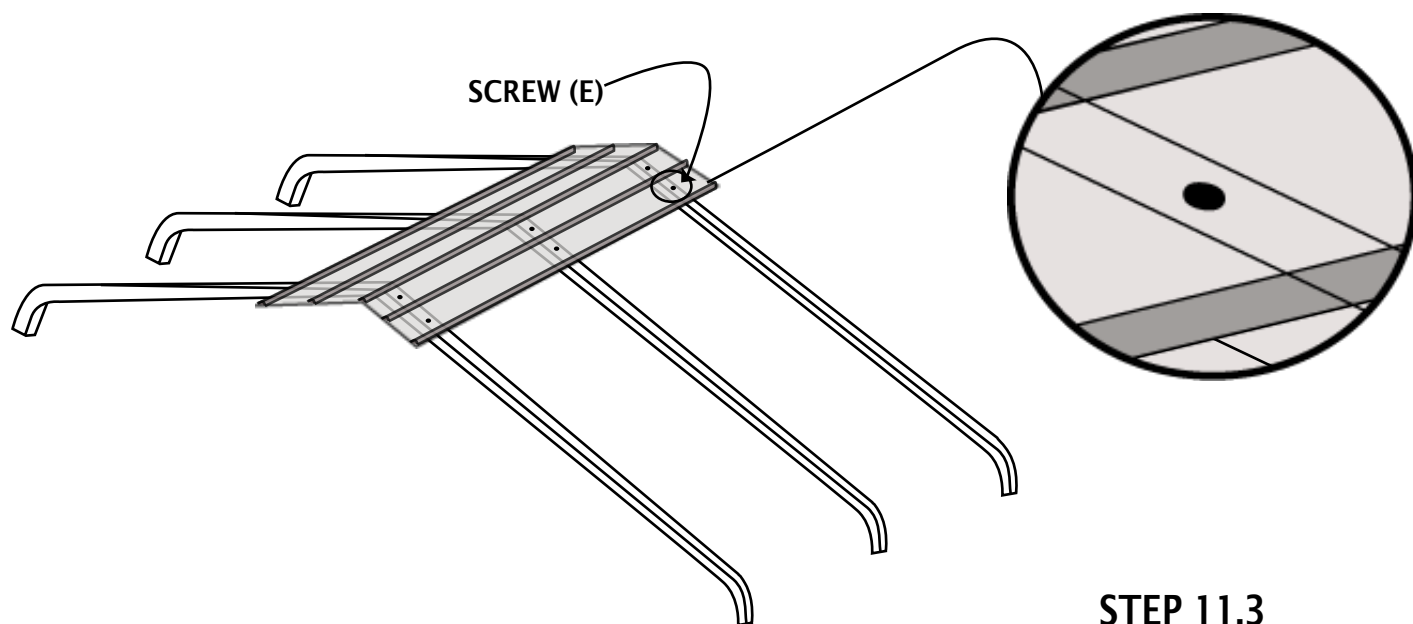

STEP 11.3

11.4 The panel assembly for 20 wide carport differs from the rest. Place a mark on the arch at 10" from the apex on any side. The first panel rib will be aligned with this mark. Therefore the second rib must be aligned at the center of each bow.

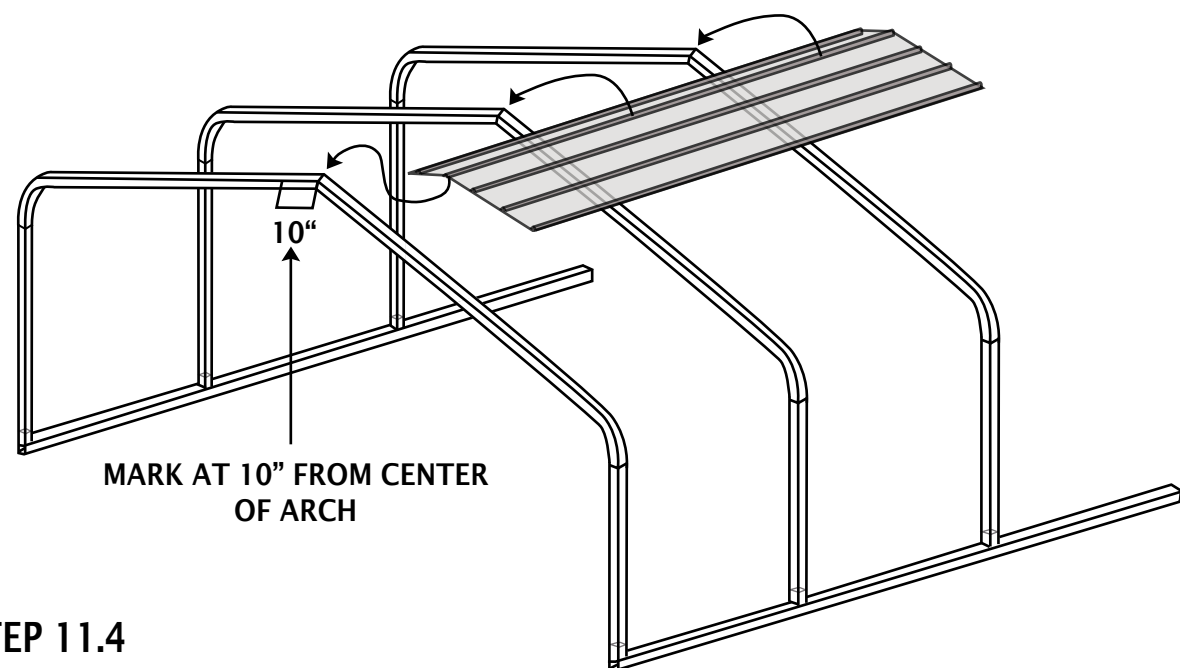

STEP 11.4

11. ROOF PANELS ASSEMBLY

11.5 Properly aligning the first panel is important as it will square up the structure. Secure the panel to the arches using the self tapping screws (E). Place one screw between second, third and fourth major ribs on each arch. At this time do not place the screws between the edge ribs. DO NOT over drive screws. Washers should be snug but not flattened. It is a good idea to pre-drill holes as it will make it easier to attach the panels.
NOTE : If more than one panel is needed to cover the length, add caulking to the top of the lapped panel.

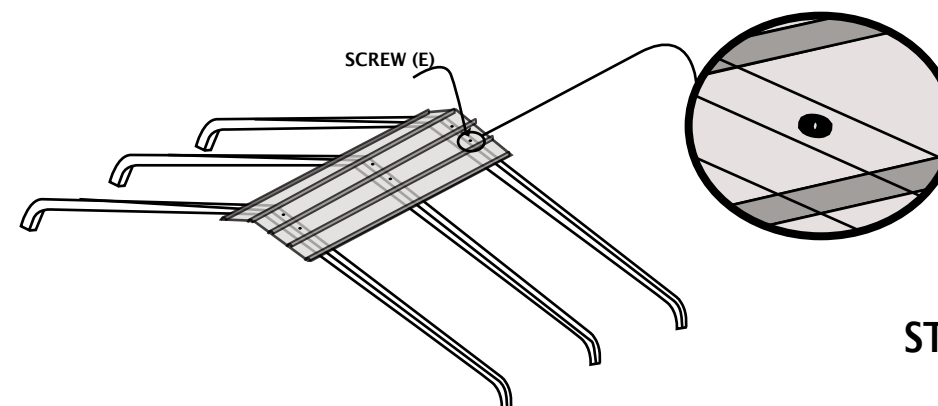

STEP 11.5

11.6 On the 20 wide carport slide second panel under first as shown below. Make sure the lipped edge of the first panel is over the lipped edge of the second panel.
NOTE : Open side of lap must always be on the down slope to prevent water penetration. Add caulking to the top of the lapped rib for better water protection.

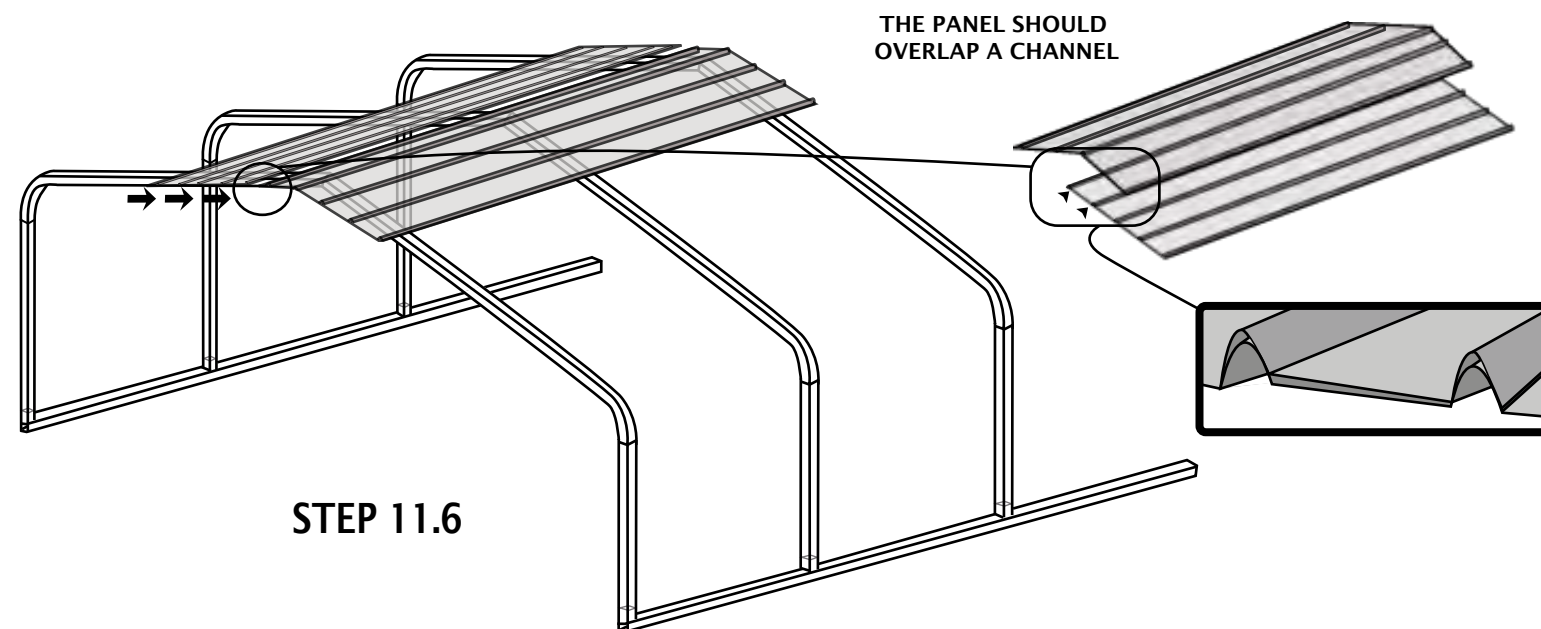

STEP 11.6

NOTE: Panels 5 and 8 only receive screws between 1st and 5th major rib.

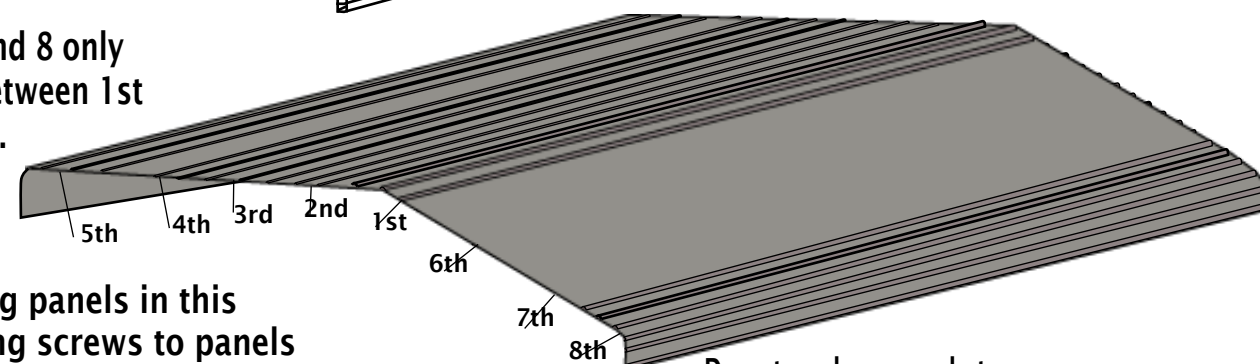

Attach remaining panels in this order by applying screws to panels at each arch, between each major rib

Do not apply screws between center ribs on 5th and 8th panel

11. ROOF PANELS ASSEMBLY

11.7 On the 12, 18, 24, 26, 28 and 30 wide carport slide second panel under the last rib on either side of the first panel as shown below. Make sure the lipped edge of the first panel is over the lipped edge of the second panel.

NOTE : Open side of lap must always be on the down slop to prevent water penetration. Add caulking to the top of the lapped rib for better water protection.

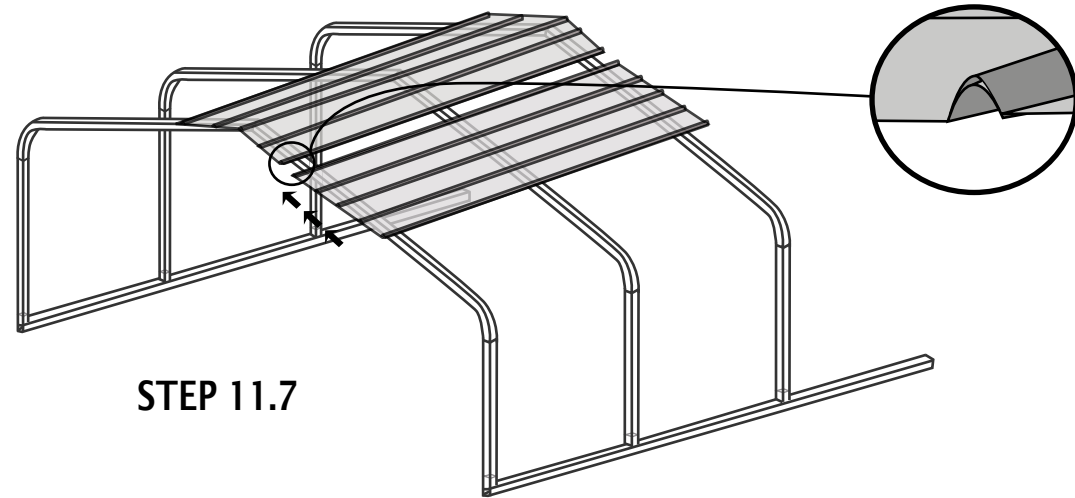

STEP 11.7

11.8 On the 22 wide carport slide second panel under first as shown below, only in this carport a whole channel of the second panel must go underneath the first panel. Continue this process for the remaining panels. Remember that a whole channel must go underneath the panel above.

THE PANEL SHOULD OVERLAP A CHANNEL

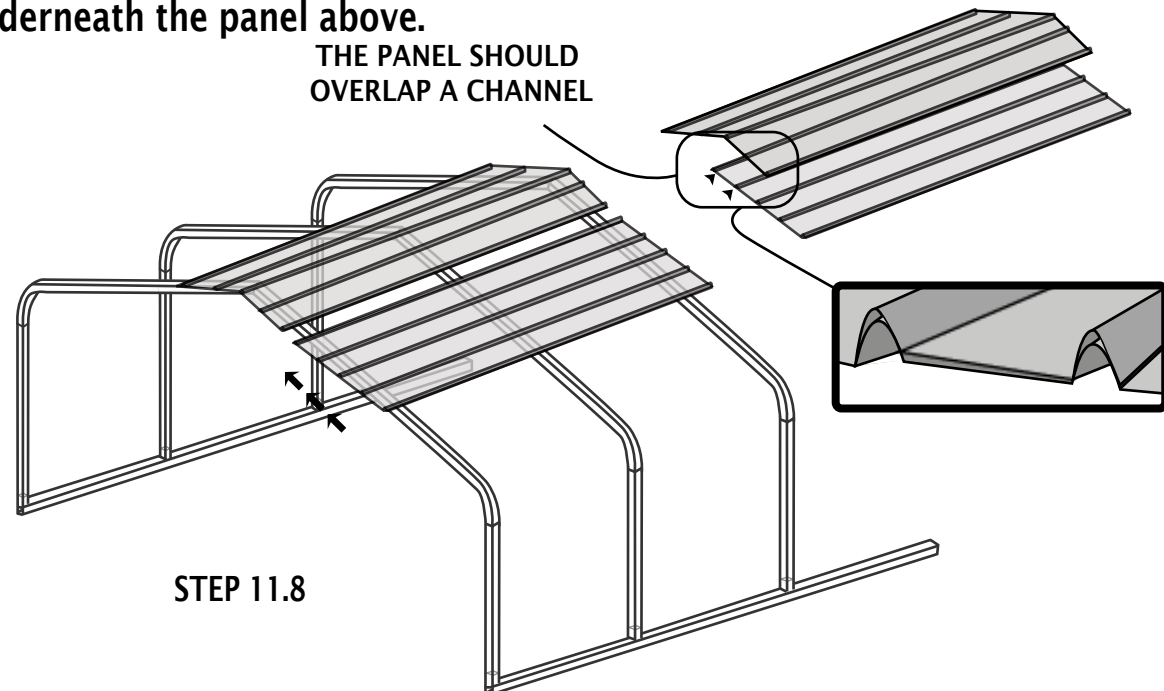

STEP 11.8

11.9 Secure the remaining screws in the first panel on the side of the second panel. For the second panel, attach all screws except those between the last and second to last ribs. These have to be secured after the next panel has been added to allow lifting of edge.

NOTICE : Continue adding panels in, according the way your panels should go, that is if only a rib must overlap, or if a whole channel must overlap, continue this process until the full area is covered.

12. TRIM ATTACHMENT

12.1 Take the two pieces of trim (F). On each mark 10" from one end and then make two marks at 9" from the same end as shown below.

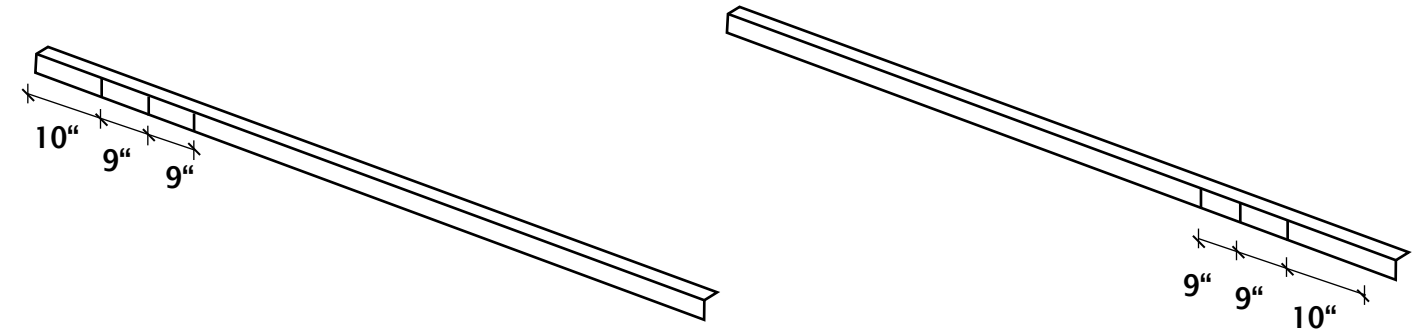

STEP 12.1

12.2 Using the tin snips, make 3 cuts only to the crease of the trim (F). DO NOT CUT ALL THE WAY THROUGH.

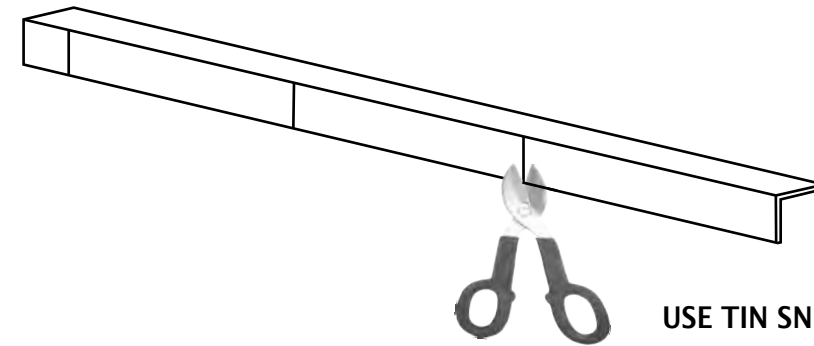

USE TIN SNIP TO CUT CREASES ON ONE SIDE

12.3 With hands, simply bend the trim at the cuts and attach to the structure with self tapping screws at every major rib from on top of the trim. Additional screws used to attach trim pieces together.

12.4 With the tin snips, cut a third piece of trim (F) in half. Cut at the center of each piece to the crease as in the previous step. Bend with hands to create a V. Attach to the structure with screws at every 9" on top of trim.

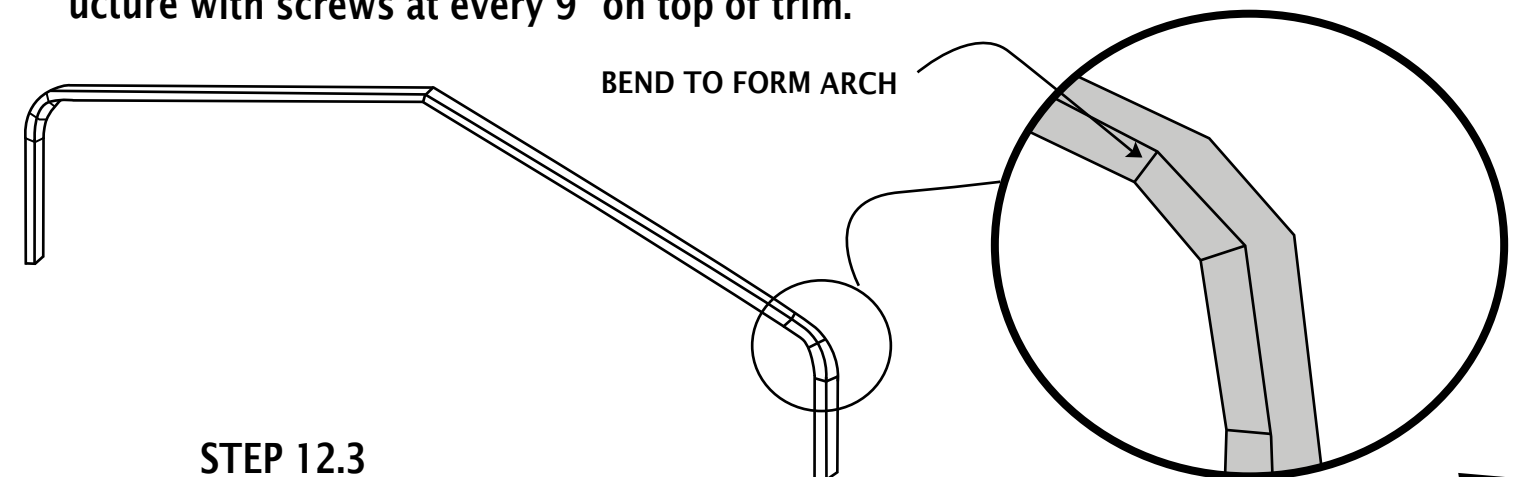

STEP 12.3

13. SECURING STRUCTURE

13.1 Using two screws per post, columns (B) to base rails (A) at the sleeve locations on the sides of the column post. This has to be done for all the columns.

13.2 Secure the remaining anchor using the procedure in step 9.

Your carport is now ready for use and should look like this:

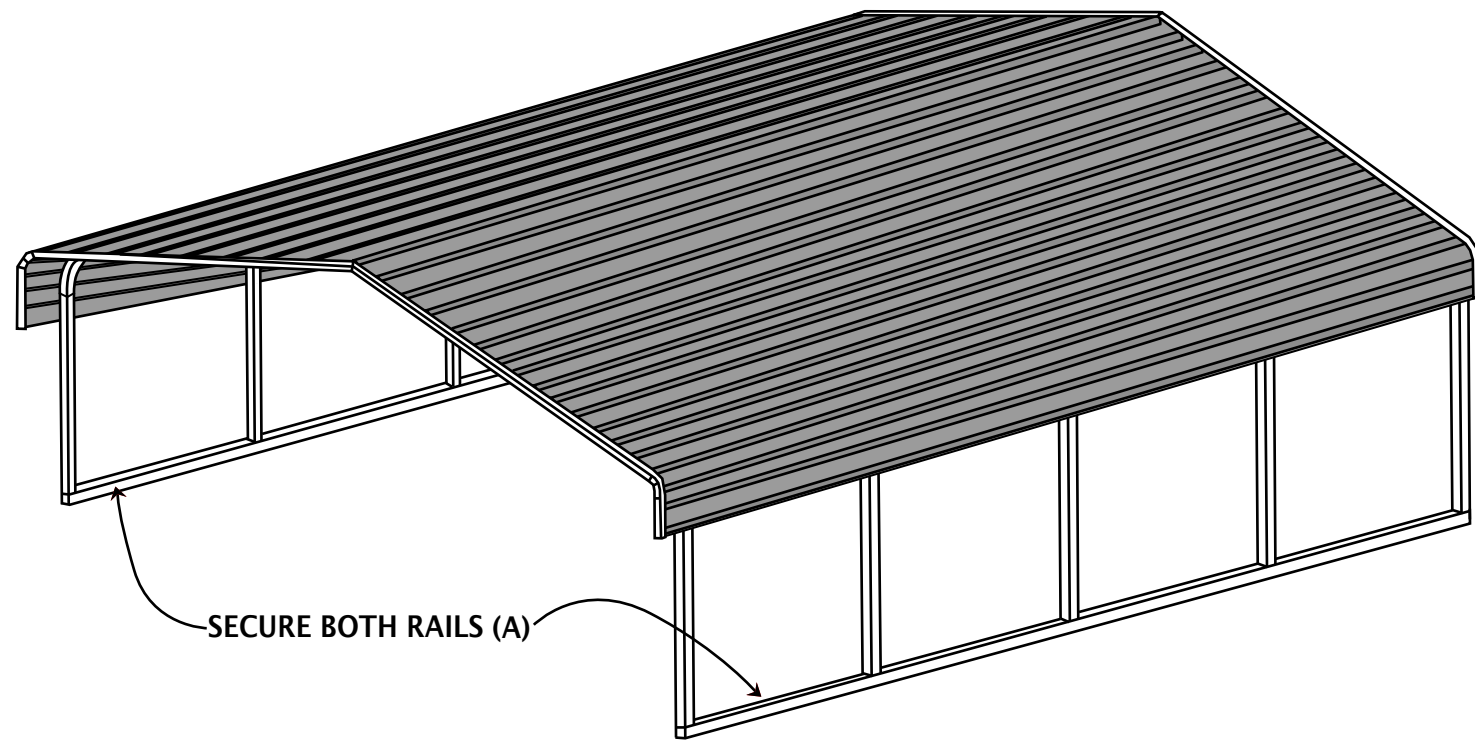

STEP 13.2

